

PALLET MASTER/SERVER - PMPS-50-DC

APPROX WEIGHT: 1002.17 lbs.
DOES NOT INCLUDE WEIGHT OF POWER OR PACKAGING!!!

*** ANY ADDITIONS, DELETIONS, OR OMISSIONS MUST BE CORRECTED ON THIS DRAWING AS THIS DRAWING WILL BE CONSIDERED ALL INCLUSIVE ***
ALL GRAPHICS PROVIDED ARE FOR REFERENCE ONLY. IF CERTAIN DIMENSIONS ARE CRITICAL PLEASE VERIFY THOSE DIMENSIONS WITH YOUR SALESPERSON

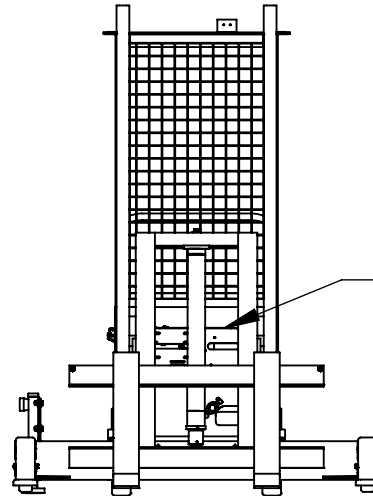
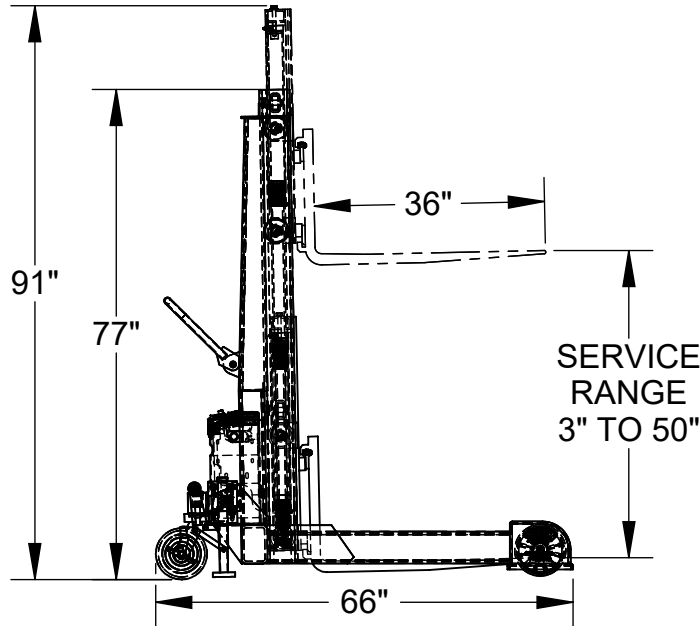
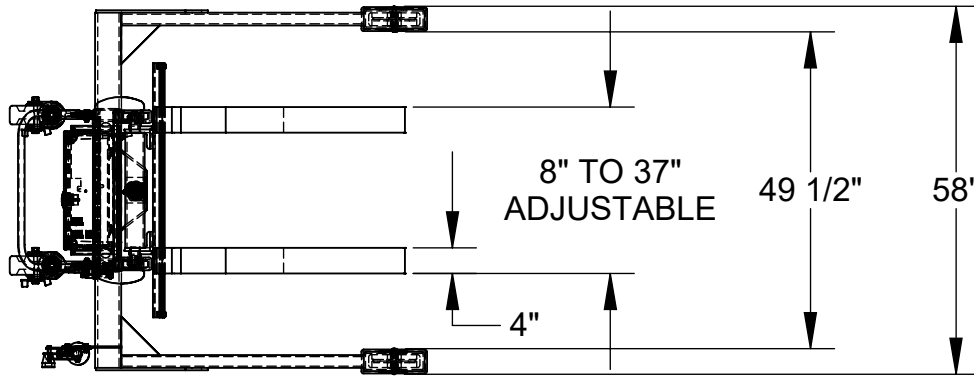

STANDARD FEATURES

- MODEL NUMBER IS PMPS-50-DC
- OVERALL WIDTH IS 58"
- STRADDLE INNER DIMENSION IS 49 1/2"
- OVERALL LENGTH IS 66"
- OVERALL RAISED HEIGHT IS 91"
- OVERALL LOWERED HEIGHT IS 77"
- MAXIMUM FORK HEIGHT BEFORE CARRIAGE EXCEEDS HEIGHT OF MAST IS 36 1/2"
- FORK CAPACITY (EVENLY DISTRIBUTED) IS 4000 LBS
- FORKS ARE 1 1/2" THICK x 4" WIDE x 36" LONG
- MAXIMUM FORK SPREAD IS 37" O.D.
- FLOOR LOCK
- 12V DC POWER UNIT
- CONTROL PENDANT W/ 8' CORD NOT SHOWN
- ALL STEEL CONSTRUCTION (ASTM A-36 MINIMUM)
- DURABLE LIQUID PAINT BLUE FINISH

SPECIAL FEATURES

NONE

12V DC POWER UNIT

DIMENSION TOLERANCE $\pm 1/4"$

PLEASE CIRCLE SPECIFICATIONS:

POWER	<input type="checkbox"/> AC	<input checked="" type="checkbox"/> DC (12V)	<input type="checkbox"/> *AIR/OIL
MOTOR VOLTAGE	<input type="checkbox"/> 115	<input type="checkbox"/> 208	<input type="checkbox"/> 230 460
DEDICATED CIRCUIT REQUIRED			
MOTOR PHASE	<input type="checkbox"/> SINGLE	<input type="checkbox"/> THREE	
CONTROL	<input checked="" type="checkbox"/> HAND	<input type="checkbox"/> * FOOT	
~ ALL BATTERY CHARGERS ARE 115V AC ~			
BATTERY CHRG.	<input type="checkbox"/> REMOTE	<input checked="" type="checkbox"/> ON-BOARD	
* CHRG. INDICATOR	<input type="checkbox"/> YES	<input type="checkbox"/> NO	

* AVAILABLE AT ADDITIONAL COST

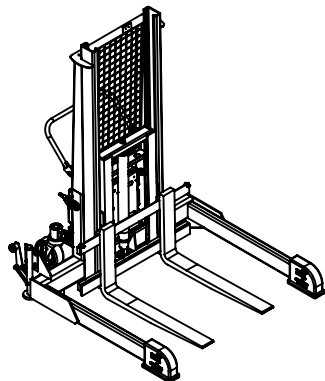

APPROVAL

I, THE UNDERSIGNED, AGREE THAT THE PRODUCT AS REPRESENTED SATISFIES DESIGN AND DIMENSION REQUIREMENTS. I ALSO ACKNOWLEDGE MY DUTY TO CONFIRM PRODUCT AND INSTALLATION COMPLIANCE WITH ALL APPLICABLE FEDERAL, STATE AND LOCAL REGULATIONS AND STANDARDS.
UNITS REQUIRING APPROVAL DRAWINGS OR MODIFIED ARE NON-RETURNABLE
[] As drawn [] As marked

Signed: _____ Date: _____

Printed Name: _____

LEAD TIME WILL START UPON RECEIPT OF SIGNED APPROVAL DRAWING

DISTRIBUTOR'S NAME:		P.O.#
VESTIL MANUFACTURING		X
DRAWN BY: A.FORD		W.O.#
DATE: 8/3/07		X
REFERENCE: X	SCALE: 1:30	SALES: X
QUOTED LEAD TIME: X	QUOTE #	FILE NAME:
	X	15-007-020